

PTFE compensator ■ Type P-2 and P-4

Lateral compensator DN 15 – DN 500



Structure type P-2

Lateral compensator consisting of a PTFE bellows and rotating flanges with tie rods (outer restraints) to absorb reaction force from internal pressure

Structure type P-4

Lateral compensator consisting of a PTFE bellows and rotating flanges with tie rods (outer and inner restraints) to absorb reaction force from internal pressure or vacuum

PTFE bellows PN 5,5 / PN 9 / PN 10,5

- Multiple convolution bellows made of PTFE
- Outer stabilizing rings of stainless steel between the convolutions
- Self-sealing PTFE flared ends
- Inner surface repellent of foreign matter

Material grade*	Possible uses
PTFE	Aggressive acids and lyes, e.g. chloride, sulphate, solvents, bleaches, peroxide, fuels, gases

*Check or inquire about the resistance of the rubber grade to temperature and medium

DN	DN 200 - 500 PN 5,5	DN 125 - 150 PN 9	DN 15 - 100 PN 10,5	Temperature
Pressure rate				
Max. perm. operating pressure	5.5 bar	9.0 bar	10.5 bar	up to +20 °C
	3.5 bar	5.5 bar	7 bar	up to +100 °C
	2.5 bar	4.0 bar	4 bar	up to +150 °C
	1.7 bar	2.5 bar	3 bar	up to +200 °C
Vacuum	≥ 0.01 bar abs. DN 15 - 150			
	≥ 0.20 bar abs. DN 200 - 250			
	≥ 0.70 bar abs. DN 300 - 500			

Max. operating pressure to be set 30 % lower for shock loads.

Flanges

Version

- Rotating flanges with ears to carry tie rods
- Drilled with threaded holes

Dimensions

Standard: DN 25 - 150 (PN 16)
DN 200 - 500 (PN 10)
according to EN 1092

Others: DIN EN, ANSI, BS etc.

Connection dimensions see technical annex

Materials

Standard: 1.0038 (S235JR)

Others: 1.4541, 1.4571

Corrosion protection

Standard: electrogalvanized

Others: hot-dip galvanized, special varnish, special coating, etc.

Applications

- for conveying aggressive media
- for compensating lateral movement
- for muffling vibration and noise
- for reducing thermal and mechanical tension
- to compensate for installation inaccuracies
- chemical industry
- treatment and disposal technology
- pharmaceutical industry

Tie rod restraints

- Tie rods carried on spherical washers and conical seats

Materials

Standard: tie rods 8.8

Others: stainless steel

Corrosion protection

Standard: electrogalvanized

Others: hot-dip galvanized

Accessories

- Internal guide sleeve of PTFE
- Protective cover

Dimensions standard program

DN	BL mm	Pres- sure rate bar	ø di Bellows inner ø mm	ø C Raised face ø mm	PN Flange connection EN 1092	ø D Flange outer ø mm	b Flange thickness mm	H Flange height mm
15	37	10.5	21.5	45	16	95	8	143
20	37	10.5	21.5	58	16	105	8	153
25	46	10.5	21.5	68	16	115	8	163
32	46	10.5	34.5	78	16	140	10	194
40	46	10.5	34.5	88	16	150	10	204
50	56	10.5	48.3	102	16	165	12	219
65	77	10.5	58.5	122	16	185	12	239
80	77	10.5	73.2	138	16	200	12	267
100	91	10.5	99.3	158	16	220	15	287
125	111	9.0	123.0	188	16	250	15	330
150	101	9.0	147.8	212	16	285	18	370
200	137	5.5	205.1	268	10	340	20	460
250	200	5.5	256.6	320	10	395	22	515
300	196	5.5	280.5	370	10	445	25	605
350	215	5.5	on request	on request	10	on request	on request	on request
400	233	5.5	on request	on request	10	on request	on request	on request
450	280	5.5	on request	on request	10	on request	on request	on request
500	327	5.5	on request	on request	10	on request	on request	on request

Larger sizes (DN), other lengths (BL), higher pressure rate, different movement compensation available on request
Dimensions according to GR 12-0040 standard available on request.

Movement compensation

DN	Δ lat Lateral movement mm	Weight approx. kg
15	4	1.7
20	4	2.1
25	6	2.3
32	6	2.8
40	6	3.1
50	9	4.3
65	9	5.1
80	13	5.8
100	13	7.5
125	14	11.9
150	14	13.2
200	14	21.5
250	14	27.7
300	15	35.8
350	on request	on request
400	on request	on request
450	on request	on request
500	on request	on request

Table values refer to +20 °C and triple-convoluted compensators

Note

Additional PTFE gaskets necessary for installation in glass, graphite or ceramic pipes.

Please comply with the general technical instructions regarding reaction force, moving force, fixed point load, installation instructions etc.

Subject to technical alterations and deviations resulting from the manufacturing process.

Flange version

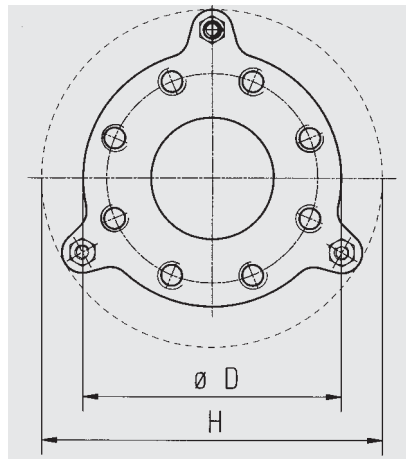

Number of tie rods depending on pressure

Versions

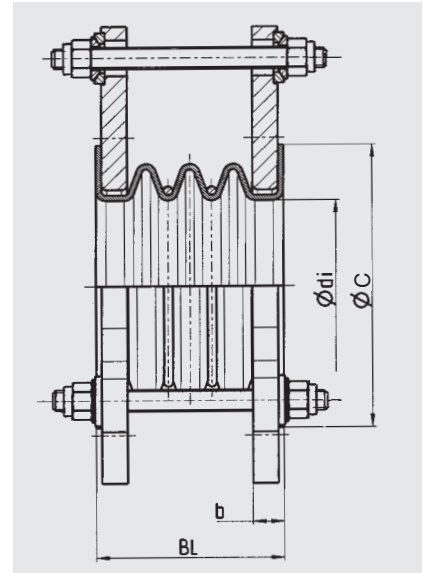

Type P-2

Lateral PTFE compensator, with tie rods (outer restraints) carried on spherical washers and conical seats

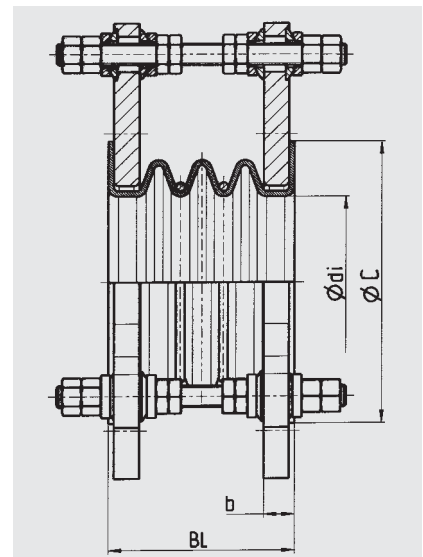

Type P-4

Lateral PTFE compensator, design as type P-2, additional inner restraints, carried on spherical washers and conical seats.